

AWG26 UL 1569

Tr5X2

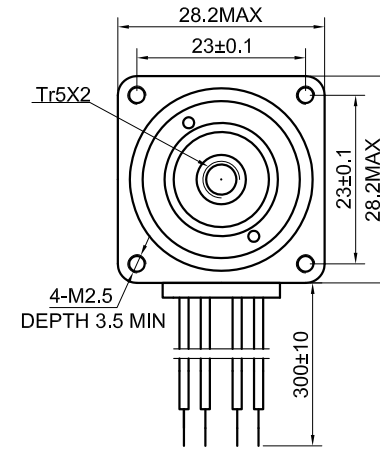
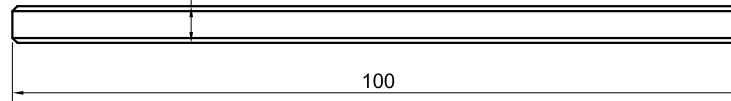

SPECIFICATION	CONNECTION	BIPOLAR
VOTAGE(VOC)		6.20
AMPS/PHASE		0.67
RESISTANCE/PHASE(Ohms)@25°C		9.20±10%
INDUCTANCE/PHASE(mH)@1KHz		5.70±20%
HOLDING TORQUE(Nm)[lb-in]		0.12[1.06]
LINEAR TRAVEL/STEP(mm)		0.01
STEP ANGLE(°)		1.80
STEP ACCURACY(NON-ACCUM)		±5.00%
ROTOR INERTIA(g-cm <sup>2</sup> )		18.00
WEIGHT(Kg)[lb]		0.20[0.44]
TEMPERATURE RISE:MAX.80°C (MOTOR STANDSTILL;FOR 2PHASE ENERGIZED )		
AMBIENT TEMPERATURE -10°C~50°C[14°F~122°F]		
INSULATION RESISTANCE 100 Mohm (UNDER NORMAL TEMPERATURE AND HUMIDITY )		
INSULATION CLASS B 130°C[266°F]		
DIELECTRIC STRENGTH 500VAC FOR 1MIN.(BETWEEN THE MOTOR COILS AND THE MOTOR CASE )		
AMBIENT HUMIDITY MAX.85%(NO CONDENSATION)		

TYPE OF CONNECTION (EXTERN)		MOTOR	
PIN NO	BIPOLAR	LEADS	WINDING
1	A —	RED	
2	A\ —	BRN	
3	B —	YEL	
4	B\ —	ORG	

FULL STEP 2 PHASE-Ex. ,  
WHEN FACING MOUNTING END (X)

STEP	A	B	A\	B\		CCW
1	+	+	-	-		
2	-	+	+	-		
3	-	-	+	+		
4	+	-	-	+		

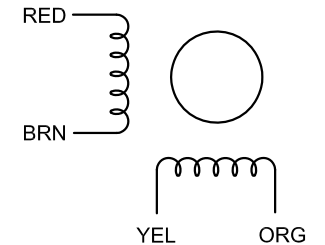

**SKYSMotor**

APVD		
CHKD		
1:1	DRN	
SCALE	SIGNATURE	DATE

**STEPPER MOTOR**

**11LS20-0674N-100B**