

GM12-N20VA

12mm gearbox plus N20 permanent magnet DC motor

Module	0.15			
Rated torque (kg.cm)	0.5 kg.cm max			
Max momentary tolerance torque (kg.cm)	1.0 kg.cm max			
Reduction ratio	1/10	1/20、1/30 1/50、1/63 1/100	1/110、1/150 1/210、1/250 1/298、1/380	1/1000
Number of gear stages	2	4	5	7
Gearbox length L (mm)	9.0		12.0	

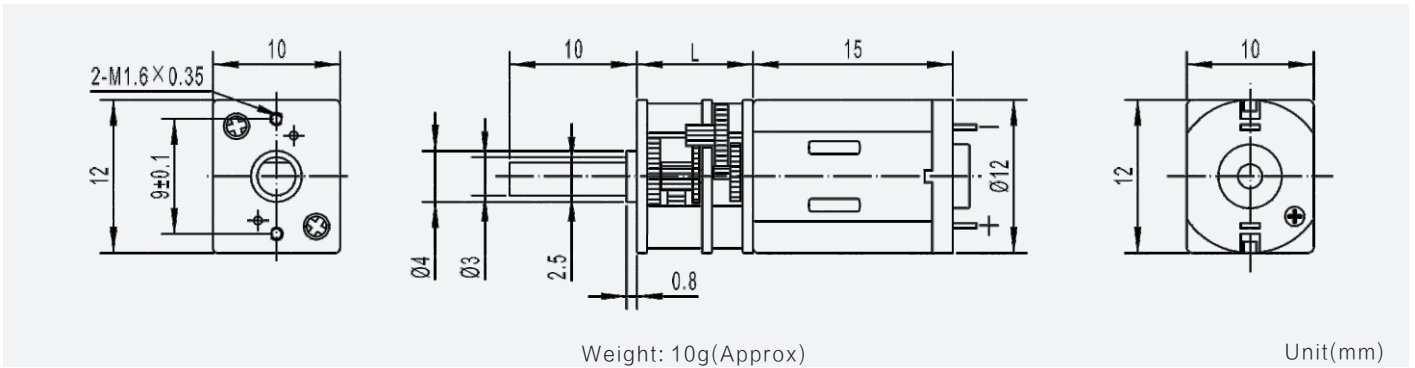
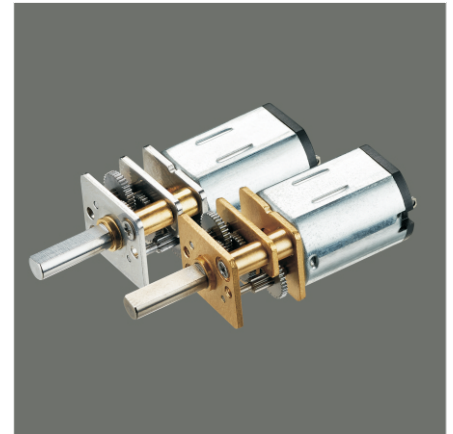

Gear Motor Technical Data

		10	30	50	100	150	210	250	298	380	1000
2.4V	Reduction ratio	10	30	50	100	150	210	250	298	380	1000
	No-load speed(rpm)	1450	470	285	145	96	69	58	50	38	14.5
	Rated speed(rpm)	1200	400	240	120	80	57	48	40	31	12
	Rated torque(kg.cm)	0.015	0.05	0.07	0.15	0.22	0.31	0.37	0.45	0.5	0.5
5.0V	No-load speed(rpm)	1450	470	285	145	96	69	58	50	38	14.5
	Rated speed(rpm)	1200	400	240	120	80	57	48	40	31	12
	Rated torque(kg.cm)	0.015	0.05	0.07	0.15	0.22	0.31	0.37	0.45	0.5	0.5

Motor Technical Data

Motor model	Rated voltage	No-load		Rated			Stall		
		Speed	Current	Speed	Torque	Current	Power	Torque	Current
	VDC	r/min	mA	r/min	g.cm	mA	W	g.cm	A
TFF-N20VA-13110	2.4	14800	60	12100	2.5	260	0.31	14	1.20
TFF-N20VA-09220	5.0	14800	30	12000	2.5	120	0.31	13	0.52

