

SKYSMotor

User Manual

CL86T(V3.0)

Closed Loop Stepper Driver



CL86T

Closed-loop Stepper Driver

24~80VDC, 8.2A Peak, Closed-loop, No Tuning

1. Introductions

This Closed-loop Stepper Driver offers an alternative for applications requiring high performance and high reliability when the servo was the only choice, while it remains cost-effective. The system includes a 2-phase stepper motor combined with a fully digital, high performance drive and an internal encoder which is used to close the position, velocity and current loops in real time, just like servo systems. It combines the best of servo and stepper motor technologies, and delivers unique capabilities and enhancements over both, while at a fraction of the cost of a servo system.

1.1 Features

- Closed-loop, eliminates loss of synchronization
- Broader operating range – higher torque and higher speed
- Reduced motor heating and more efficient
- Smooth motion and super-low motor noise
- Do not need a high torque margin
- No Tuning and always stable
- Quick response, no delay and almost no settle time
- High torque at starting and low speed, high stiffness at standstill
- Offer servo-like performance at a much lower cost

1.2 Applications

Its great feature of quick response and no hunting make this Closed-loop Stepper Driver ideal for applications such as bonding and vision systems in which rapid motions with a short distance are required and hunting would be a problem. And it is ideal for applications where the equipment uses a belt-drive mechanism or otherwise has low rigidity and you don't want it to vibrate when stopping.

2. Specifications

2.1 Electrical Specifications

Parameter	Min	Typical	Max	Unit
Input Voltage	24	48	80	VDC
Output Current	0	-	8.2	A
Pulse Input Frequency	0	-	200	kHz
Logic Signal Current	7	10	16	mA
Isolation Resistance	500	-	-	MΩ

2.2 Operating Environment



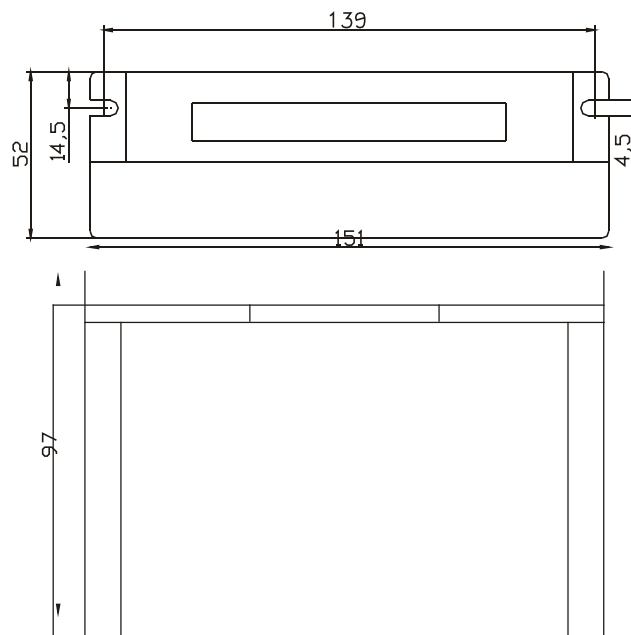

Cooling	Natural Cooling or Forced cooling	
Operating Environment	Environment	Avoid dust, oil fog and corrosive gases
	Storage Temperature	-20°C — 65°C (-4°F — 149°F)
	Ambient Temperature	0°C — 50°C (32°F — 122°F)
	Humidity	40%RH — 90%RH
	Operating Temperature (Heat Sink)	70°C (158°F) Max
Storage Temperature	-20°C — 65°C (-4°F — 149°F)	
Weight	580 g (20.5 oz)	

2.3 Mechanical Specifications

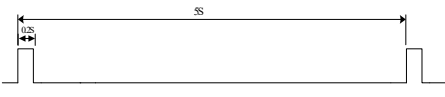
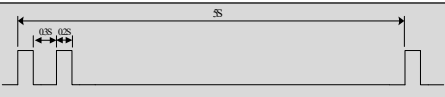
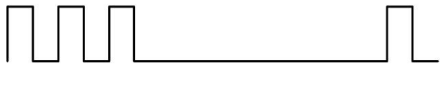

2.4 Protection and Troubleshooting

The green indicator turns on when power-up. When drive protection is activated, the red LED blinks periodically to indicate the error type.

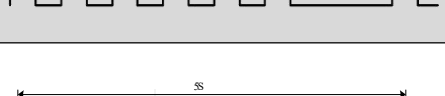
Blink time(s)	Sequence wave of red LED	Description	Trouble shooting
1		Over-current	Turn off the power immediately. a) Check wiring is short-circuited or not; b) Check motor is short-circuited or not.
2		Over-voltage	Turn off the power immediately. a) Check if the power voltage is higher than 110VDC
3		Chip error	Restart the power supply, if the drive is still alarm, please contact after-sale
4		Fail to lock motor shaft	a) The drive is not connected to a motor; b) If alarm is occurred when connect a motor, set DIP switch SW6 to 'on' and restart power supply; If it still alarm, please check the motor power cable.
5		EEPROM error	Restart the power supply, if the drive is still alarm, please contact after-sale
6		Fail to auto tuning	Set DIP switch SW6 to 'on'
7		Position following error	a) The value of position following error is set too small; b) Motor torque is not enough or motor speed is too high; c) Motor wiring error, check wiring
Always	-	PCB board is burned out	Contact after-sale a) Power supply connection is wrong

3. Connectors and Pin Assignment

The CL86T has four connectors, connector for control signals connections, connector for status signal connections, connector for encoder feedback and connector for power and motor connections.

Pin Name	I/O	Details
PUL+	I	Pulse signal: (1) . In single pulse (pulse & direction) control mode, this input represents pulse signal. A pulse signal is active at the rising or falling voltage edge (set by PC software). (2) In double-pulse (CW/CCW) control mode (set by PC software), this signal input represents clockwise (CW) pulse, and is active at both high voltage level and low voltage level. (3) 4.5-5V for voltage HIGH, 0-0.5V for voltage LOW (same for DIR and ENA signals). (4) Pulse width should be set to 2.5 μ s or longer.
PUL-	I	
DIR+	I	Direction signal: (1) In single pulse (step & direction) control mode, this signal's low and high voltage levels represent the two directions of motor rotation (e.g. clockwise and counterclockwise). (2) In double-pulse (CW & CCW) control mode, this signal represents counterclockwise (CCW) rotation. It is active at both voltage high level and low level. (3) Minimal DIR signal setup time should be at least 5 μ s. (4) Rotation direction is related to your motor/drive wiring. You can reverse the default rotation direction by toggling the SW5 DIP switch.
DIR-	I	
ENA+	I	Enable signal: This signal is used for enabling/disabling the drive. High voltage level of 4.5-24V (NPN control signal) for enabling the drive and low voltage level of 0-0.5VDC for disabling the drive. PNP and Differential control signals are on the contrary, namely Low level for enabling. By default this signal is left UNCONNECTED & ENABLED .
ENA-	I	
Pend+	O	Configurable Digital Output Signal: A configurable OC output signal. It takes a sinking or sourcing 20mA current at 5-24V. It can to be configured as one of the 2 types, <i>IN POSITION</i> (default), or <i>BRAKE CONTROL</i> through PC software.
Pend-	O	
ALM+	O	Fault Signal: An OC output signal which is active when one of the following error protection is activated: over-voltage, over-current, and position following error. This port can sink or source 20mA current at 5-24V. The resistance between ALM+ and ALM- is low impedance in normal operation, and will change to high when the drive goes into error protection. The voltage active level of this fault output signal can be configured by configuration software.
ALM-	O	

Encoder Feedback Connector – Screw Terminal			
Pin	Name	I/O	Description
1	EB+	I	Encoder channel B+ input
2	EB-	I	Encoder channel B- input
3	EA+	I	Encoder channel A+ input
4	EA-	I	Encoder channel A- input
5	VCC	O	+5V @ 100 mA max.
6	EGND	GND	Signal ground

Power and Motor Connector – Screw Terminal			
Pin	Name	I/O	Description
1	A+	O	Motor Phase A+
2	A-	O	Motor Phase A-
3	B+	O	Motor Phase B+
4	B-	O	Motor Phase B-
5	+Vdc	I	Power Supply Input (Positive) 30-72VDC recommended, leaving room for voltage fluctuation and back-EMF.
6	GND	GND	Power Ground (Negative)

RS232 Communication Port

It is used to configure the close-loop current, open-loop current, position following error limit and etc. See Closed-loop Stepper Driver software operational manual for more information.

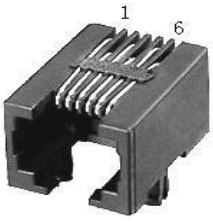
RS232 Communication Port				
Pin	Name	I/O	Description	
1	NC	-	Not connected.	
2	+5V	O	+5V power only for STU (Simple Tuning Unit).	
3	TxD	O	RS232 transmit.	
4	GND	GND	Ground.	
5	RxD	I	RS232 receive.	
6	NC	-	Not connected.	

4. DIP Switch Settings

4.1 Microstep Resolution (SW1-SW4)

Steps/Revolution	SW1	SW2	SW3	SW4
Software Configured (Default 1600)	on	on	on	on
800	off	on	on	on
1600	on	off	on	on
3200	off	off	on	on
6400	on	on	off	on
12800	off	on	off	on
25600	on	off	off	on
51200	off	off	off	on
1000	on	on	on	off
2000	off	on	on	off
4000	on	off	on	off
5000	off	off	on	off
8000	on	on	off	off
10000	off	on	off	off
20000	on	off	off	off
40000	off	off	off	off

4.2 Motor Direction (SW5)

	ON	OFF
SW5	Motor direction is positive.	Motor direction is negative.

Note: The actual motor direction is also related to DIR level.

4.3 Motor Selection (SW6)

	Function	On	Off
SW6	Auto Tuning	No	Yes

4.4 Current Control

The motor current will be adjusted automatically regarding to the load or the stator-rotor relationship. However, the user can also configure the current in the tuning software. The configurable parameters include close-loop current, holding current, encoder resolution, micro step and etc.

5. Typical Connections

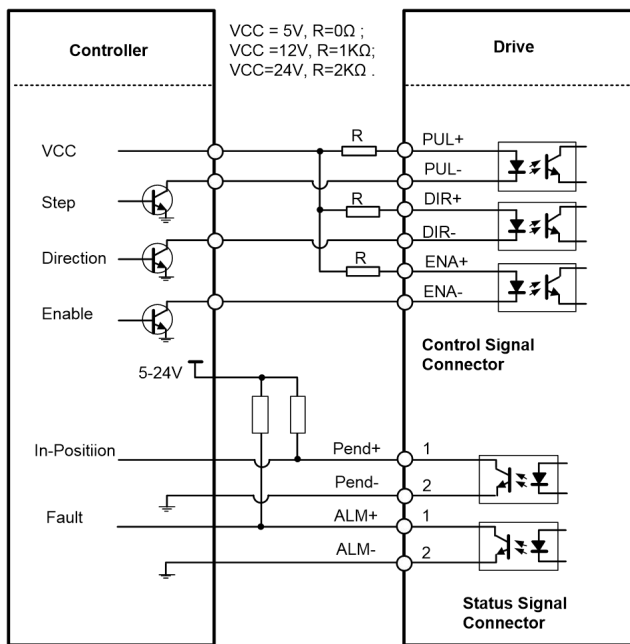

Connections to open-collector signal (common-anode)

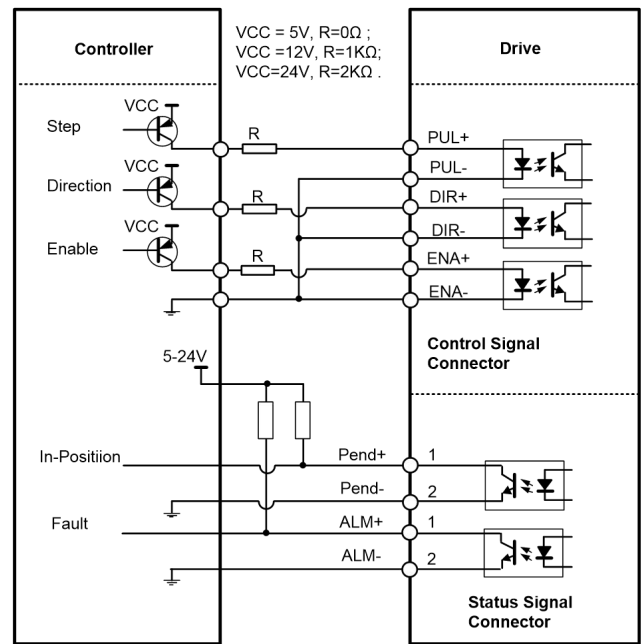

Connections to controller of sourcing output (common-cathode)

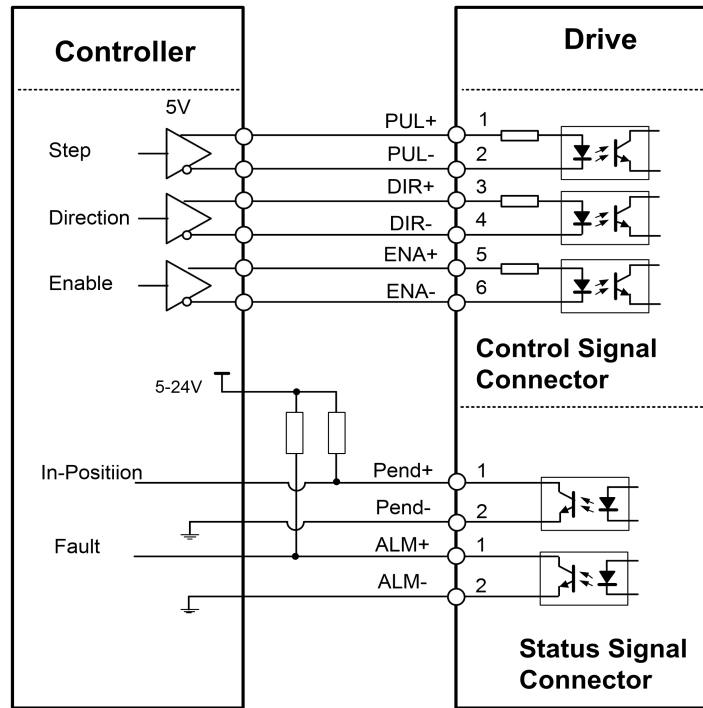

Connections to controller of differential output