

SKYSMotor

DM860S

Digital Stepper Drive

Manual

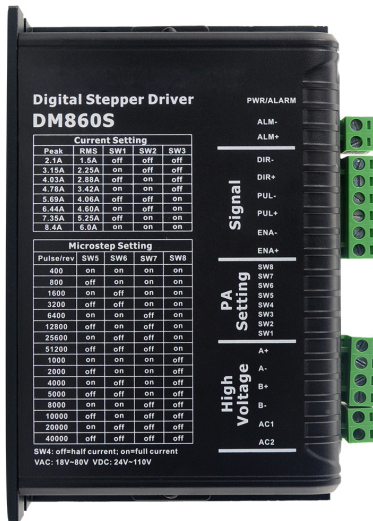

Contents

1. Overview.....	1
2. Features.....	1
3. Ports Introduction.....	2
3.1 Control Signal Input Ports.....	2
3.2 Power Interface Ports.....	3
3.3 Alarm Output Ports.....	3
4. Technological Index.....	4
5. Connections to Control Signal.....	5
5.1 Connections to Common Anode.....	5
5.2 Connections to Common Cathode.....	6
5.3 Connections to Differential Signal.....	7
5.4 232 serial communication wiring diagram.....	7
5.5 Sequence Chart of Control Signals.....	8
6. DIP Switch Setting.....	9
6.1 Current Setting.....	9
6.2 Standstill current Setting.....	9
6.3 Microsteps Setting.....	10
7. Faults alarm and LED flicker frequency.....	11
8. Appearance and Installatlon Dimensions.....	12
9. Typical Connection.....	12
10. Parameter Setting.....	13
11. Frequently Asked Questions.....	18

1. Overview

The DM860S is a two phase digital stepper driver based on 32-bit DSP technology. The microstep resolution and output current can be set by users. It has advanced control algorithm which brings a unique level of system smoothness, provides optimum torque and mid-range instability. The control algorithm of Multi-Stepping can allow stepper motor a smooth system performance. The control algorithm of torque compensation can improve the torque of motor at high speed. The control algorithm of motor self-test and parameter auto-setup offers optimum responses with different motors and easy-to-use. The control algorithm of smoothness can enhance the acceleration and deceleration of motor. Its unique features make the DM860S an ideal solution to applications.

2. Features

- ◆ Parameter auto-setup and motor self-test
- ◆ Multi-Stepping inside, Small noise, low heat, smooth movement
- ◆ Torque compensation at high speed
- ◆ Variable current control technology, High current efficiency
- ◆ Accelerate and decelerate control inside, Great improvement in smoothness of starting or stopping the motor
- ◆ Support PUL/DIR and CW/CCW modes
- ◆ Storage the position of motor
- ◆ Optically isolated input and compatible with 5V ~ 24V
- ◆ User-defined microsteps

- ◆ Micro-step resolutions and Output current programmable
- ◆ Over current, over voltage and under voltage protection
- ◆ Green light means running while red light means protection or off line

3. Ports Introduction

3.1 Control Signal Input Ports

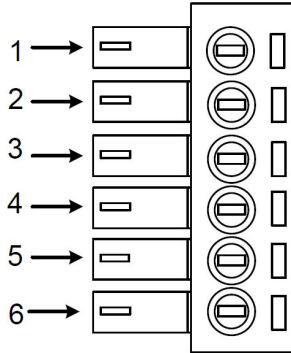

Port	Symbol	Name	Remark
1	PLS+	Pulse signal +	Compatible with 5V ~ 24V
2	PLS-	Pulse signal -	
3	DIR+	Direction signal+	
4	DIR-	Direction signal-	
5	ENA+	Enable signal +	
6	ENA-	Enable signal-	

3.2 Power Interface Ports

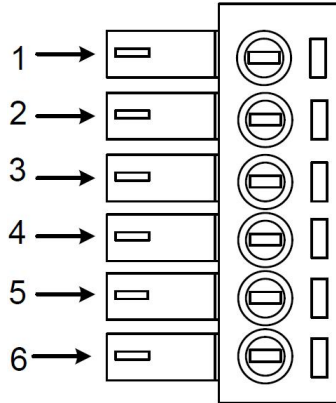

Port	Symbol	Name	Remark
1	A+	Phase A+	Motor Phase A
2	A-	Phase A-	
3	B+	Phase B+	Motor Phase B
4	B-	Phase B-	
5	+V	Input Power +	DC 30 ~ 110V/ AC 24 ~ 80V
6	GND	Input Power -	

3.3 Alarm Output Ports

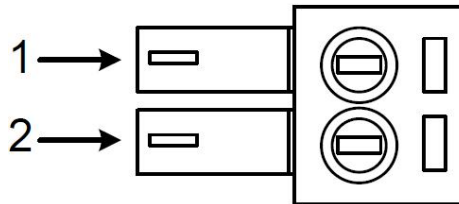

Port	Symbol	Name	Remark
1	ALM+	Alarm output +	Open collector output+
2	ALM-	Alarm output -	Open collector output-

4. Technological Index

Input Voltage		DC 30 ~ 110V/ AC 24 ~ 70V
Continuous Current		7.5A
Max Pulse Frequency		200k
Default communication rate		57.6kbps
Protection		Overcurrent protection, peak $12A \pm 10\%$
		Over voltage protection value 130VDC
		Under voltage protection value 20VDC
Overall Dimensions(mm)		150×97.5×53
Weight		Approximate 580g
Environment	Environment	Avoid dust, oil fog and corrosive gases
	Operating Temperature	0 ~ 70°C
	Storage Temperature	-20°C~+80°C
	Humidity	40~90%RH
	Cooling method	Natural cooling or forced air cooling

5. Connections to Control Signal

5.1 Connections to Common Anode

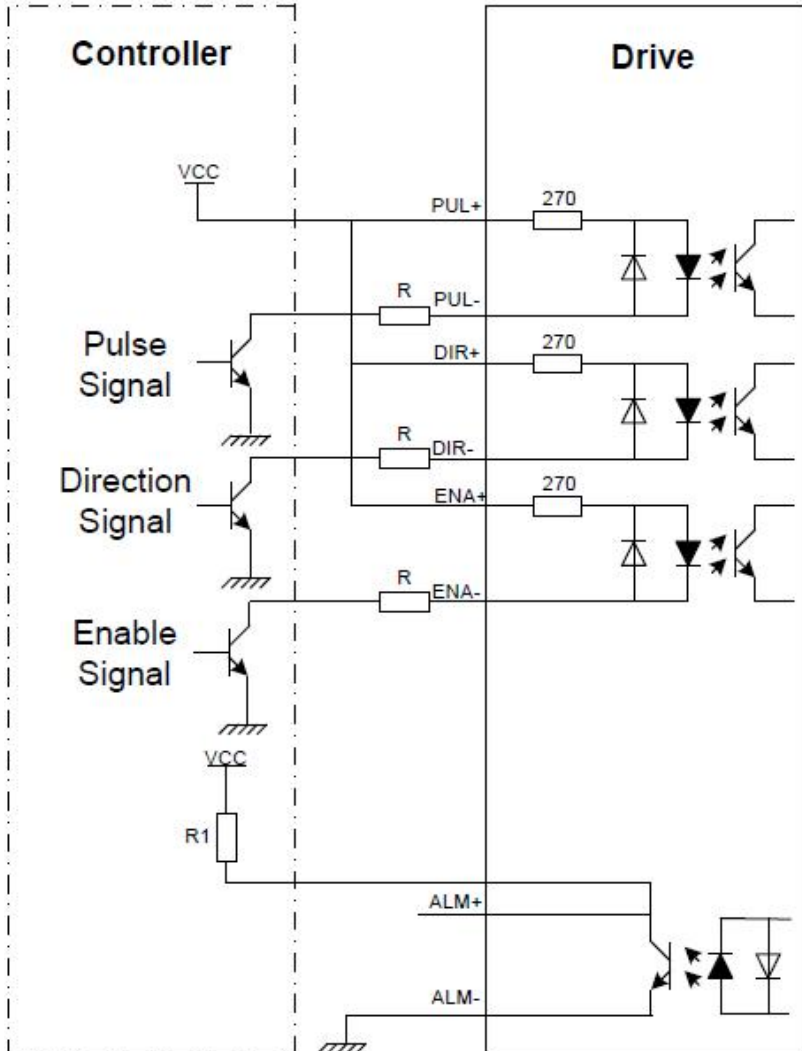

Remark:

VCC is compatible with 5V ~ 24V;

The R1 is connected to the control signal terminal and has a resistance of 3~5K.

5.2 Connections to Common Cathode

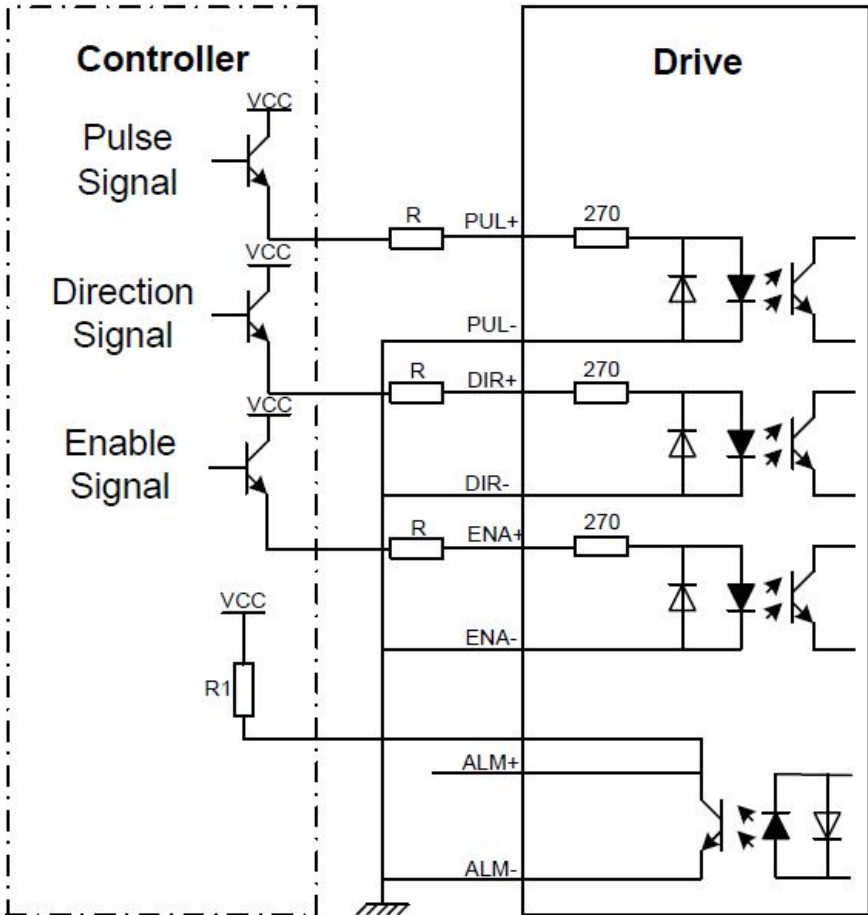

Remark:

VCC is compatible with 5V or 24V;

The R1 is connected to the control signal terminal and has a resistance of 3~5K .

5.3 Connections to Differential Signal

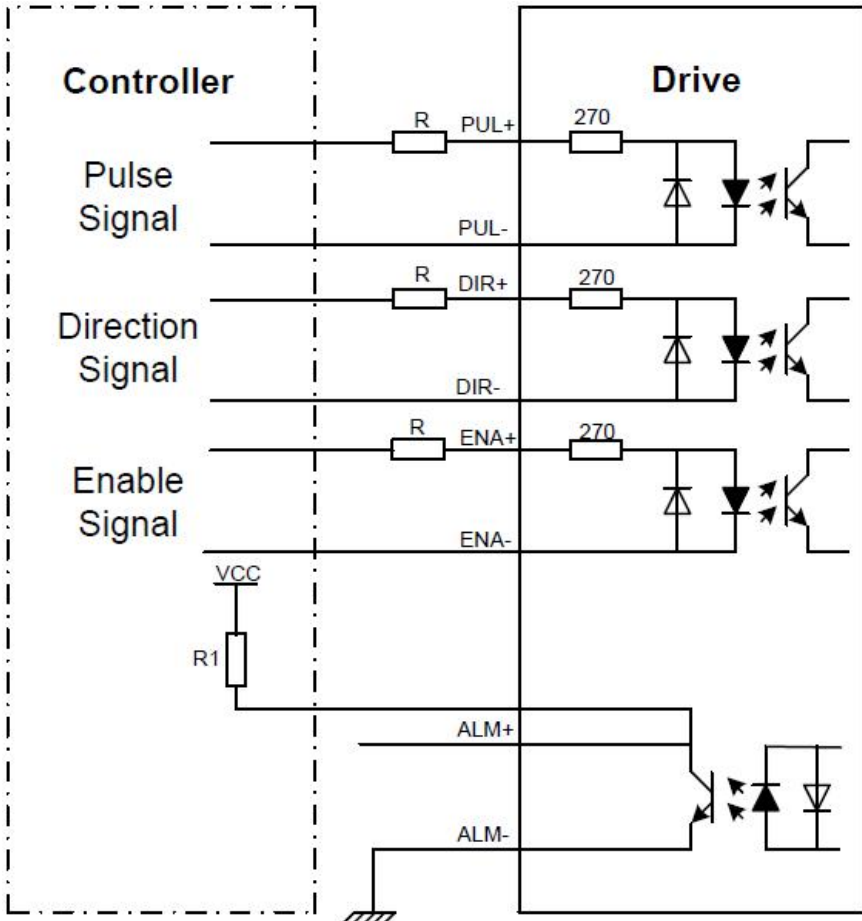

Remark:

VCC is compatible with 5V ~ 24V.

The R1 is connected to the control signal terminal and has a resistance of 3~5K.

5.4 232 serial communication wiring diagram

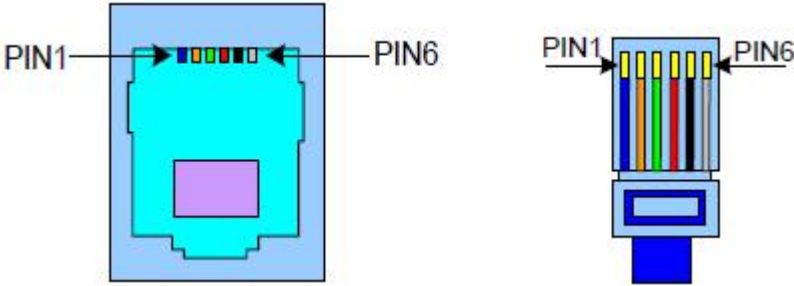

Crystal Head foot	Definition	Remark
1	TXD	Transmit Data
2	RXD	Receive Data
4	+5V	Power Supply for HISU
6	GND	Power Ground

5.5 Sequence Chart of Control Signals

In order to avoid some fault operations and deviations, PUL, DIR and ENA should abide by some rules, shown as following diagram:

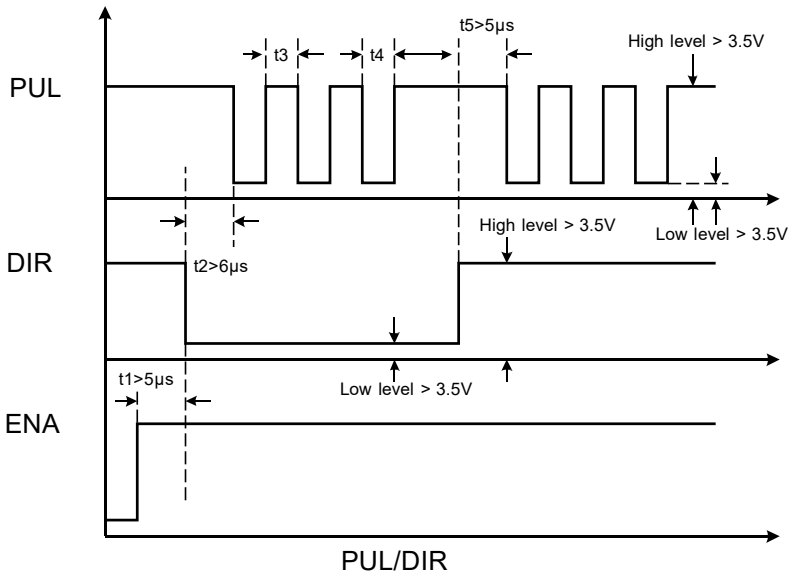

Remark:

- a. t1: ENA must be ahead of DIR by at least 5μ s. Usually, ENA+ and ENA- are NC (not connected).
- b. t2: DIR must be ahead of PUL active edge by 6μ s to ensure correct direction;
- c. t3: Pulse width not less than 2.5μ s;
- d. t4: Low level width not less than 2.5μ s.

6. DIP Switch Setting

6.1 Current Setting

The current setting is in the following table.

Current		Dial		SW1	SW2	SW3
		Peak	RMS			
2.1A	1.5A	off	off	off	off	off
3.15A	2.25A	on	off	off	off	off
4.03A	2.88A	off	on	off	on	off
4.78A	3.42A	on	on	on	on	off
5.69A	4.06A	off	off	off	off	on
6.44A	4.60A	on	off	on	off	on
7.35A	5.25A	off	on	off	on	on
8.4A	6.0A	on	on	on	on	on

6.2 Standstill current Setting

SW4 is used for setting the standstill current , “off” means the standstill current is set to be half of the selected dynamic current or other current, which can be set by the HISU, the details can be seen in the tenth sections. While “on” means the standstill current is set to be the same as the selected dynamic current.

6.3 Microsteps Setting

The microsteps setting is in the following table. And the microsteps can be also setting through the HISU.

Dial switch Microsteps	SW5	SW6	SW7	SW8
400	on	on	on	on
800	off	on	on	on
1600	on	off	on	on
3200	off	off	on	on
6400	on	on	off	on
12800	off	on	off	on
25600	on	off	off	on
51200	off	off	off	on
1000	on	on	on	off
2000	off	on	on	off
4000	on	off	on	off
5000	off	off	on	off
8000	on	on	off	off
10000	off	on	off	off
20000	on	off	off	off
40000	off	off	off	off

7. Faults alarm and LED flicker frequency

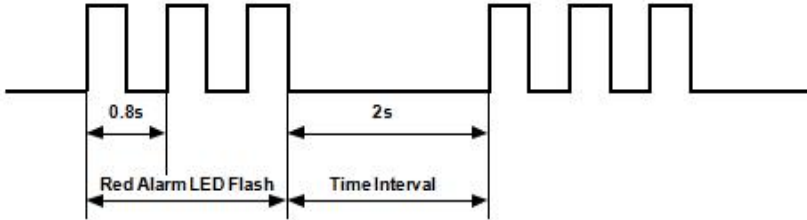

Flicker Frequency	Description to the Faults
1	Error occurs when the motor coil current exceeds the drive's current limit.
2	Voltage reference error in the drive
3	Parameters upload error in the drive
4	Error occurs when the input voltage exceeds the drive's voltage limit.

8. Appearance and Installatlon Dimensions

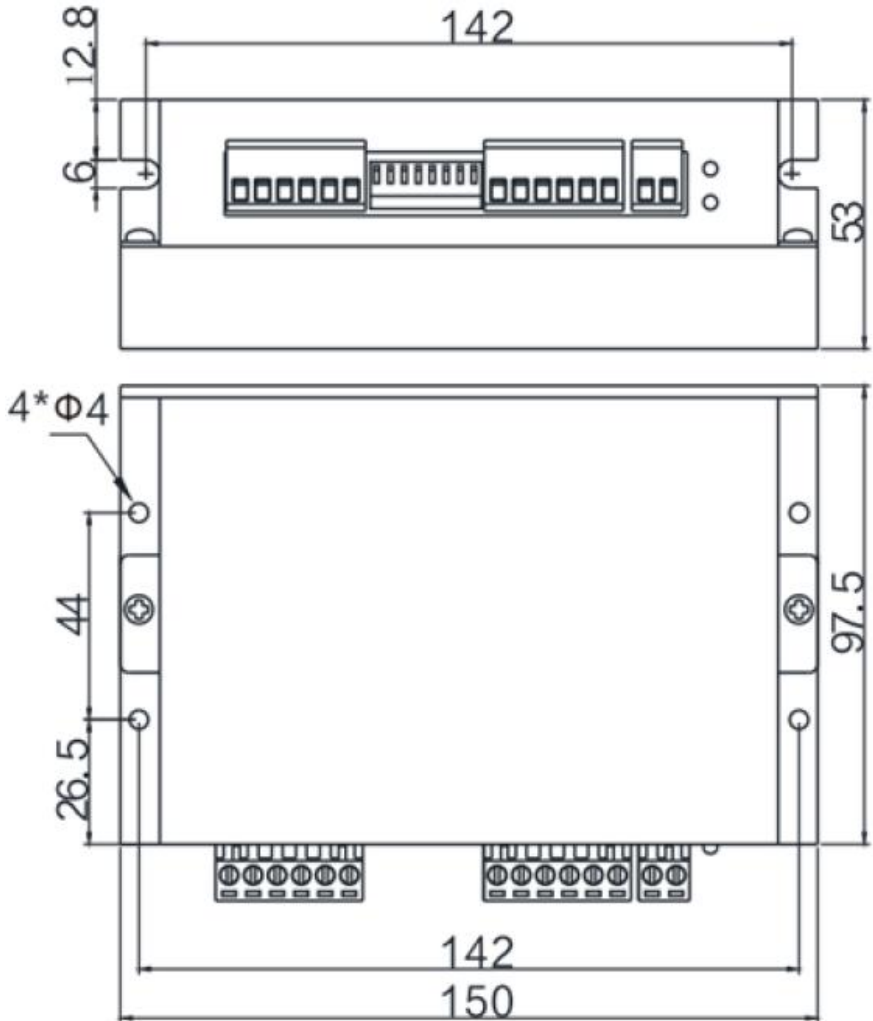

9. Typical Connection

Here is the typical connection of DM860S.

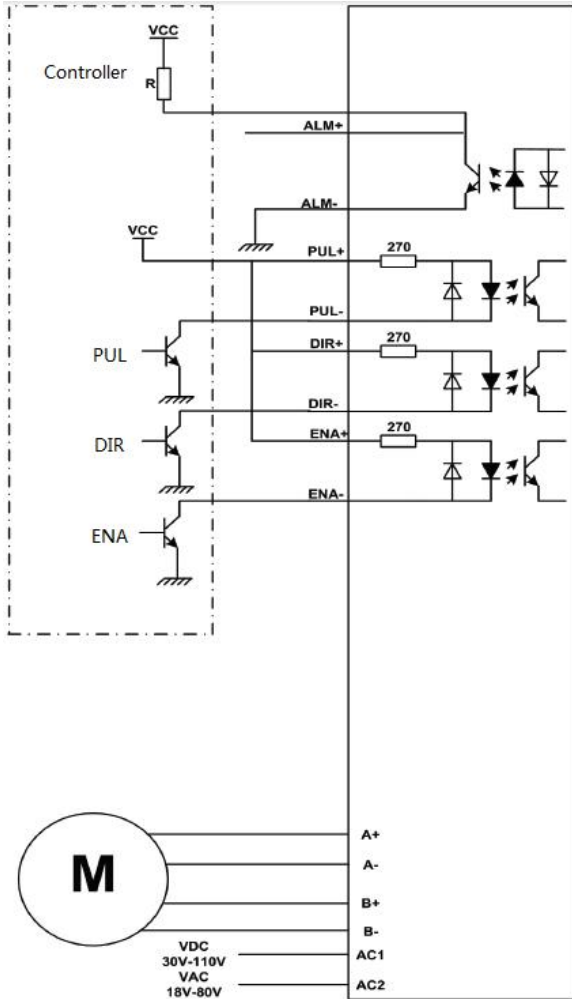

10. Parameter Setting

The parameter setting method of DM860S drive is to use a HISU adjuster through the 232 serial communication ports, only in this way we can set the parameters we want. There are a set of best default parameters to the corresponding motor which are carefully adjusted by our engineers, users only need refer to the

following table, specific condition and set the correct parameters.

Actual value = Set value × the corresponding dimension

Mode	Definition	Range	Dimension	Drive Restart	Default Value
P0	Drive restoration	0—100	1		11
P1	Current loop Kp	0—4000	1	Y	1000
P2	Current loop Ki	0—1000	1	Y	100
P3	Damping coefficient	0—500	1	N	100
P4	Amplitude of first resonance point	0—100	1	N	0
P5	Phase of first resonance point	0—100	1	N	0
P6	Amplitude of second resonance point	0—100	1	N	0
P7	Phase of second resonance point	0—100	1	N	0
P8	Damping coefficient	0—1000	1	N	120
P9	Reserved				
P10	Enable signal level	0—1	1	N	0
P11	Initial direction selection	0—1	1	N	1
P12	Reserved				
P13	Control mode selection	0—1	1	N	0

P14	User-defined microsteps	4—1000	50	Y	0
P15	Time of standstill current	0—4000	1ms	Y	1000
P16	Percentage of standstill current	0—100	1	Y	50
P17	Speed smoothness	0—10	1	Y	0
P18	Enable of position memory	0—1	1	Y	0
P19	User-defined resistance of motor	0—100	mh	Y	0
P20	User-defined inductance of motor	0—100	0.1ohm	Y	0
P21	Result of position memory	0—128	1		0
P22	Time of enable position memory	0—100	1S	Y	5

There are total 22 parameter configurations, use the HISU to download the configured parameters to the drive, the detail descriptions to every parameter configuration are as follows:

Item	Description
Current loop Kp (P1) Current loop Ki (P2)	The P1 and P2 is used to set Kp and Ki of Current loop at the moment of power-on. When the motor is turning, the Kp and Ki is got by the Self-tuning algorithm.
Damping coefficient (P3)	This parameter is used to change the damping coefficient in case of the desired operating state is under resonance frequency. This parameter is useful in high speed.

<p>Amp 1—2 Phase 1—2 (P4, P5, P6, P7)</p>	<p>DM860S Driver provides robust anti-resonance control to stop the vibrations and maintain equilibrium. Amp1 and Phase1 is Phase adjustment for 1st and Amplitude adjustment for 1st resonance area respectively. Usually between 0.6rps and 1.2rps. Amp2 and Phase2 is Phase adjustment for 2nd and Amplitude adjustment for 2nd resonance area respectively. Usually between 1.2rps and 2.4rps.</p>
<p>Anti-resonance coefficient (P8)</p>	<p>This parameter is used for reducing resonance. Usually between 3rps and 4rps.</p>
<p>Enable signal level (P10)</p>	<p>This parameter is set to control the Enable Input signal level. 0 means low, while 1 means high.</p>
<p>Pulse edge selection (P11)</p>	<p>This parameter is set to choose the pulse edge.0 means the pulse signal is valid for the rising edge,while 1 means the pulse signal is valid for the falling edge.</p>
<p>Control mode selection(P13)</p>	<p>0 means PUL / DIR mode while 1 means CW / CCW mode.When using the CW/CCW mode, make sure that the port with no pulse signal is low level.</p>
<p>User-defined microsteps ((P14)</p>	<p>This parameter is set of user-defined Microsteps. The actual Microsteps = the set value × 50. For example, if the parameter is 80, the Microsteps is 80 × 50 =4000. But if this parameter is 0, which means microsteps is set by the outer DIP switches.</p>
<p>Time of standstill current (P15)</p>	<p>This parameter is set the time when the standstill current is set to be half of the selected dynamic current or other current.</p>
<p>Percentage of standstill current (P16)</p>	<p>This parameter is set the percentage of standstill current.</p>

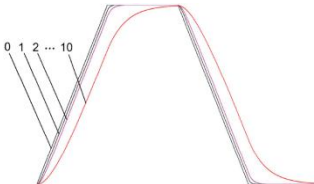
<p>Speed smoothness (P17)</p>	<p>This parameter is set to control the smoothness of the speed of the motor while acceleration or deceleration, the larger the value, the smoother the speed in acceleration or deceleration.</p> 
<p>Enable of position memory (P18)</p>	<p>This parameter is set to enable the function of position memory. 0 means disable, while 1 means enable. If set 1, the DM860S can remember the position of motor in the next time of power on.</p>
<p>User-defined inductance of motor (P19)</p>	<p>This parameter is set the inductance of motor. 0 means DM860S gets the inductance by control algorithm of Parameter auto-setup, while 1 means DM860S gets the inductance through user sets.</p>
<p>User-defined resistance of motor (P20)</p>	<p>This parameter is set the resistance of motor. 0 means DM860S gets the resistance by control algorithm of Parameter auto-setup, while 1 means DM860S gets the resistance through user sets.</p>
<p>Result of position memory (P21)</p>	<p>Display the result of position memory</p>
<p>Time of enable position memory(P22)</p>	<p>This parameter is used to set how long the pulse stops before starting the position memory function</p>

11. Frequently Asked Questions

11.1 The power light is off

- No power input, please check the power supply circuit.
- The voltage is too low.

11.2 The drive alarms when power on

- Please check the motor is connected with the drive.
- The stepper digital drive is over voltage or under voltage. Please lower or increase the input voltage.

11.3 The motor does not rotate after being given pulse signals

- Please check the input pulse signal wires are connected in reliable way.
- Please make sure the input pulse mode is corresponding with the real input mode.
- The Driver is disabled.