

# GM20-20BY

20mm gearbox plus 20mm stepper motor

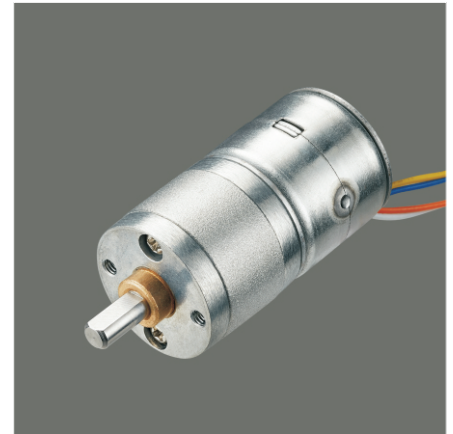

Module	0.25/0.3/0.35			
Rated torque (kg.cm)	2.5 kg.cm max			
Max momentary tolerance torque (kg.cm)	5.0 kg.cm max			
Reduction ratio	1/29、1/31	1/56、1/60 1/73、1/78	1/107、1/115 1/140、1/150 1/182、1/195	1/268、1/287 1/349、1/374 1/456、1/488
Number of gear stages	4	5	6	7
Gearbox length L (mm)	15.9	17.4	18.9	20.4

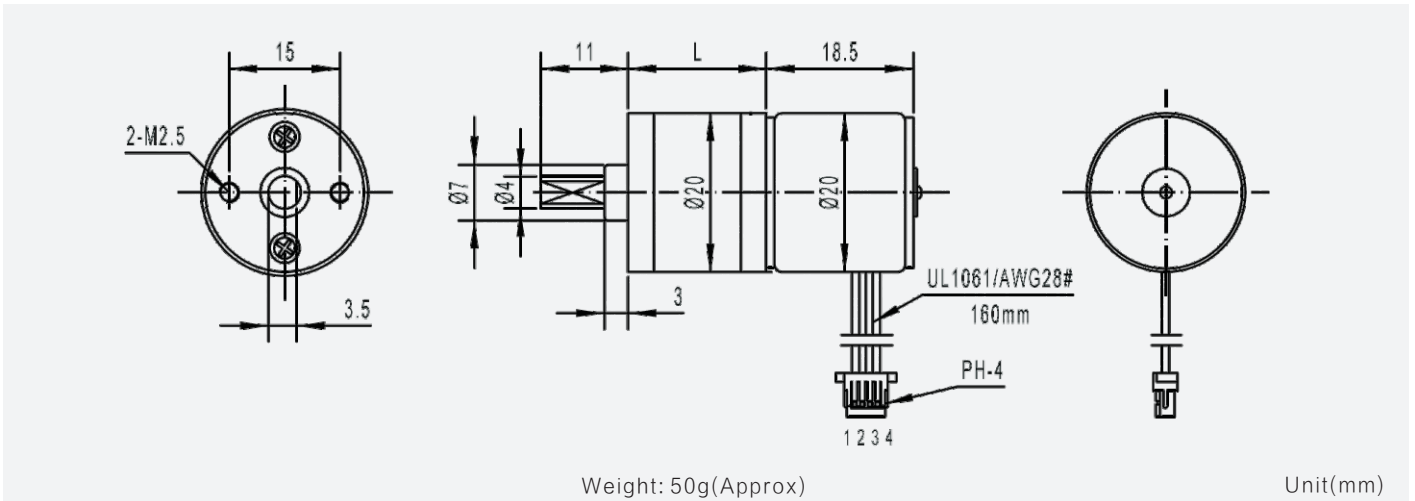

## Motor Technical Data

Motor model	Rated voltage	No. of phase	Step angle	Resistance	Current	Inductance	Detent torque	Holding torque	Pull in rate
	VDC			$\Omega$	mA	mH	g.cm	g.cm	pps
TS-20BY-001	12.0	2	18°	60	200		10	30	700

