

## GMP10-10BY

10mm planetary gearbox plus 10mm stepper motor

Module	0.2			
Rated torque (kg.cm)	0.5 kg.cm max			
Max momentary tolerance torque (kg.cm)	1.0 kg.cm max			
Reduction ratio	1/16	1/64	1/256	1/1024
Number of gear stages	2	3	4	5
Gearbox length L (mm)	12	15	18	21

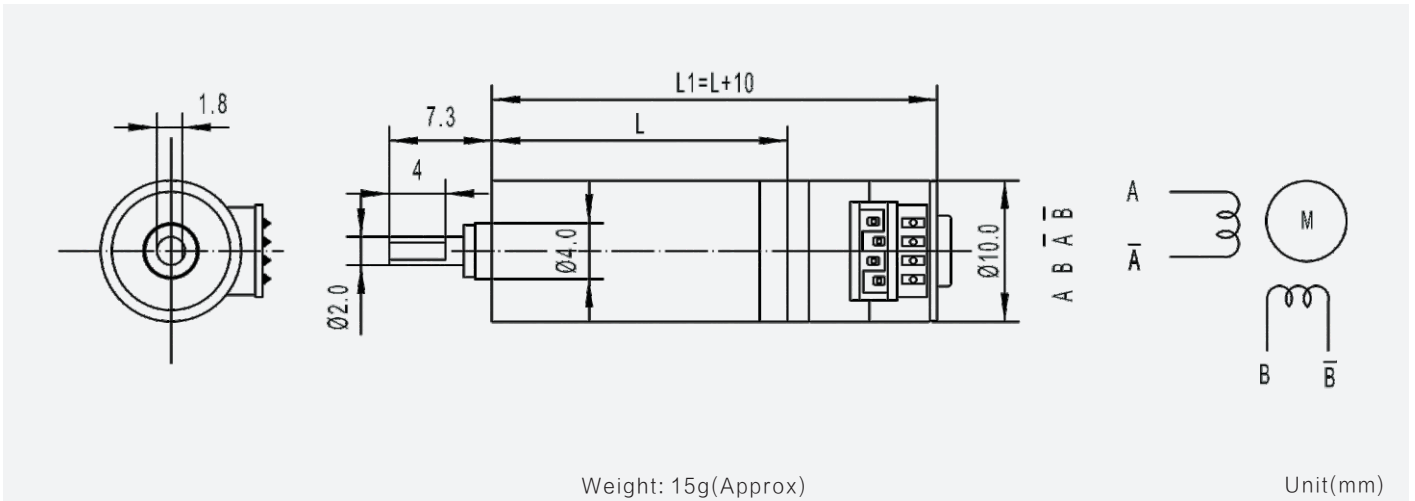

### Motor Technical Data

Motor model	Rated voltage	No. of phase	Step angle	Resistance	Current	Inductance	Detent torque	Holding torque	Pull in rate
	VDC			$\Omega$	mA	mH	g.cm	g.cm	pps
<b>TS-10BY-001</b>	3.3	2	18°	12.2	270			5	1200

