

# GMP16-050SH

16mm planetary gearbox plus 050 permanent magnet DC motor

Module	0.3				
Rated torque (kg.cm)	2.4 kg.cm max				
Max momentary tolerance torque (kg.cm)	4.8 kg.cm max				
Reduction ratio	1/4	1/14, 1/16 1/19, 1/29	1/53, 1/62 1/84, 1/104 1/157	1/231, 1/316 1/370, 1/455	1/850 1/1996
Number of gear stages	1	2	3	4	5
L (mm)	15.1	18.7	22.4	26.0	29.7

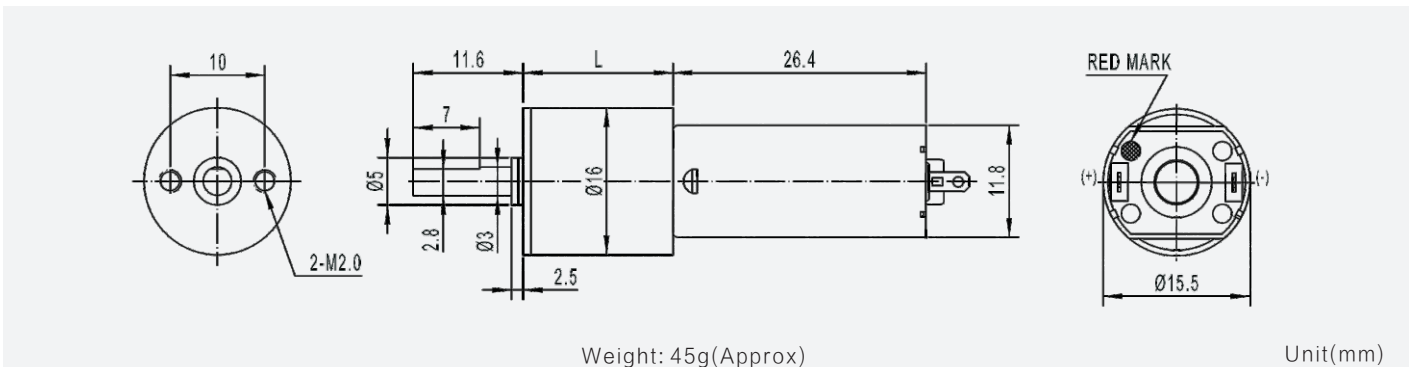

## Gear Motor Technical Data

		4	16	29	62	104	198	231	370	850	1996
6.0V	Reduction ratio	4	16	29	62	104	198	231	370	850	1996
	No-load speed(rpm)	3000	750	420	195	115	56	53	33	14	6
	Rated speed(rpm)	2500	625	345	160	96	50	43	27	12	5
	Rated torque(kg.cm)	0.03	0.11	0.2	0.4	0.6	1.0	1.2	2.2	2.4	2.4
12.0V	No-load speed(rpm)	3100	770	430	200	120	65	55	35	15	6
	Rated speed(rpm)	2450	600	335	150	90	48	40	26	12	5
	Rated torque(kg.cm)	0.03	0.11	0.2	0.4	0.6	1.0	1.2	2.2	2.4	2.4

## Motor Technical Data

Motor model	Rated voltage	No-load		Rated			Stall		
		Speed	Current	Speed	Torque	Current	Power	Torque	Current
	VDC	r/min	mA	r/min	g.cm	mA	W	g.cm	A
TFF-050SH-13120	6.0	12500	45	10000	10	255	1.03	50	1.30
TFF-050SH-08240	12.0	12800	35	9700	10	150	0.99	41	0.55

