

# GMP28-385PA

28mm planetary gearbox plus 385 permanent magnet DC motor

Module	0.5			
Rated torque (kg.cm)	20.0 kg.cm max			
Max momentary tolerance torque (kg.cm)	40.0 kg.cm max			
Reduction ratio	1/4	1/14 1/19 1/27	1/51、1/71 1/100、1/139	1/189、1/264 1/369、1/516 1/720
Number of gear stages	1	2	3	4
L (mm)	28.5	36	43	50

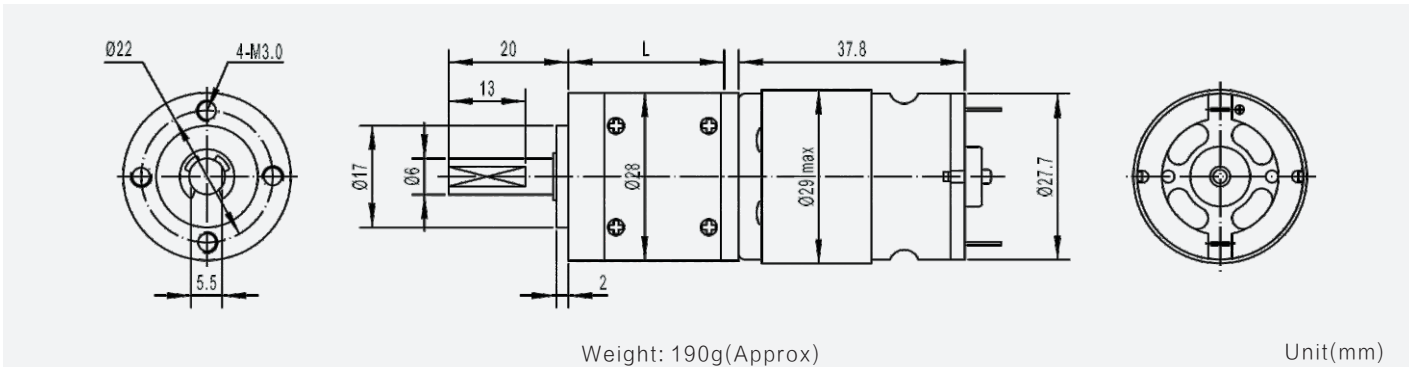

## Gear Motor Technical Data

Reduction ratio		4	19	27	51	100	189	264	369	516	720
12.0V	No-load speed(rpm)	1500	330	230	120	63	34	23	16	12	8
	Rated speed(rpm)	1300	270	190	100	52	27	20	14	10	7
	Rated torque(kg.cm)	0.2	0.8	1.1	1.8	3.6	6	8	11	15	17
24.0V	No-load speed(rpm)	1250	270	190	100	50	29	20	15	10	8
	Rated speed(rpm)	1000	210	150	78	40	21	15	11	8	6
	Rated torque(kg.cm)	0.2	0.8	1.1	1.8	3.6	6	8	11	15	17

## Motor Technical Data

Motor model	Rated voltage	No-load		Rated			Stall		
		Speed	Current	Speed	Torque	Current	Power	Torque	Current
	VDC	r/min	mA	r/min	g.cm	mA	W	g.cm	A
TRS-385PA-1265	12.0	6500	150	5200	60	500	3.2	300	2.0
TRS-385PA-2454	24.0	5400	100	4100	60	220	2.5	250	0.6

