

TWG1220-N30VA

12x20mm worm gearbox plus N30 permanent magnet DC motor

Module	0.2/0.3		
Rated torque (kg.cm)	1kg. cm max		
Max momentary tolerance torque (kg.cm)	2.0 kg.cm max		
Reduction ratio	1/40, 1/80 1/95, 1/190	1/219, 1/438	1/504, 1/1007
Number of gear stages	4	5	6
Gearbox length L (mm)	20.0		

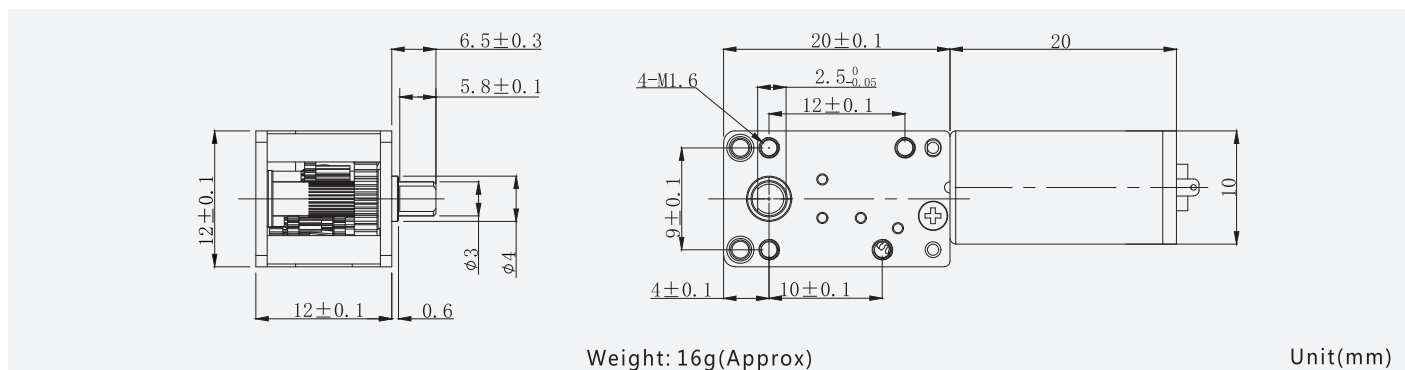

Gear Motor Technical Data

	Reduction ratio	40	80	95	190	219	438	504	1007		
		6.0V	No-load speed(rpm)	312	156	130	65	57	28	25	12
	Rated speed(rpm)	265	132	112	56	48	24	21	10		
	Rated torque(kg.cm)	0.035	0.07	0.085	0.17	0.2	0.4	0.5	1		
12.0V	No-load speed(rpm)	312	156	130	65	57	28	25	12		
	Rated speed(rpm)	260	130	109	55	47	24	20	10		
	Rated torque(kg.cm)	0.035	0.07	0.085	0.17	0.2	0.4	0.5	1		

Motor Technical Data

Motor model	Rated voltage	No-load		Rated				Stall	
		Speed	Current	Speed	Torque	Current	Power	Torque	Current
	VDC	r/min	mA	r/min	g.cm	mA	W	g.cm	A
TFF-N30VA-09190	6.0	12500	25	10600	3.0	98	0.33	20	0.50
TFF-N30VA-06350	12.0	12500	12	10400	3.0	50	0.32	18	0.25

